

e-smart 306
high performance
clear reflector
compact fluorescent
luminaries

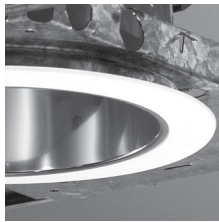

COMMERCIAL
Energy efficient
high colour rendering
electronic ballast
low maintenance
lighting

Saving up to 80% energy
from halogen, each 52W
e-smart downlight
provides lighting equal to
three 90-Watt halogen
recessed potlights over an
area of up to 80 sq. feet

Glass Trims suffix -GT

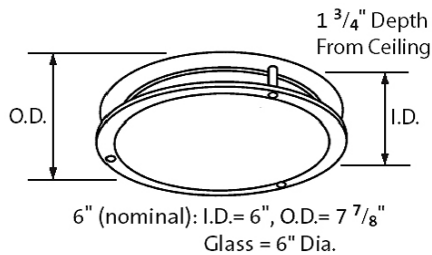

Specular Trims

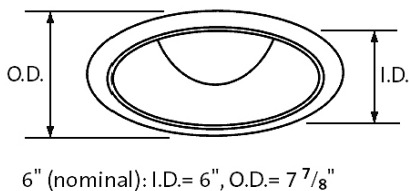

6" Flat Frame-in For Vertical CF Lamp

306 Series

Electronic Ballast - Five Year Warranty

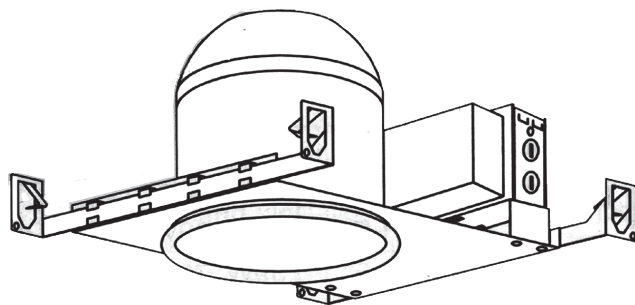

DIMENSIONS

Ceiling Cut-Out : 6-1/2"
Plaster frame : 7-5/8"W x 12"L
Lamp : Max. 52W

Cat. 3063

Max. 52W
3600 lm - 13000 hrs

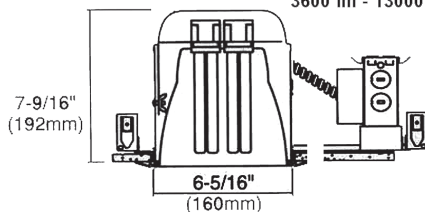

Cat. 3060

Max. 42W
3200 lm - 10000 hrs

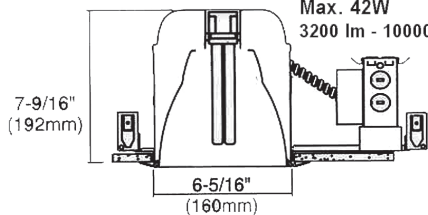

Cat. 3066

Max. 23W
1400 lm - 6000 hrs

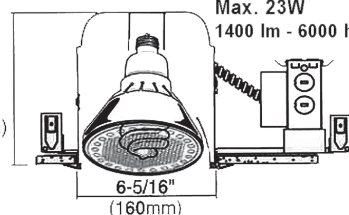

Cat. 3066

Max. 34W
2100 lm - 7000 hrs

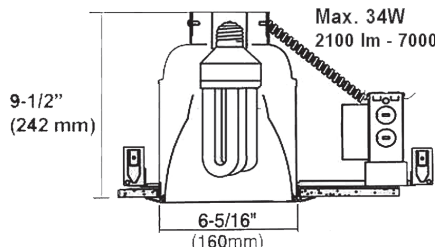

Cat. 3066

Max. 42W
3200 lm - 10000 hrs

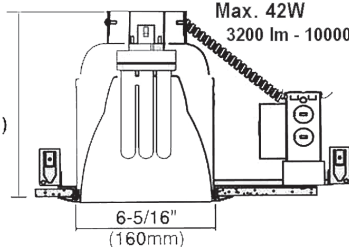

Clear reflector **e-smart** compact fluorescent downlights deliver the correct blend of brightness, contrast, colour rendering, glare control and visual comfort to provide the ultimate energy savings required by today's commercial spaces.

Electronic ballast guarantees flicker free lamp operation, extends lamp life and provides improved lamp lumen maintenance.

e-smart downlights deliver unparalleled system efficiency and energy reducing capabilities, plus ease of maintenance and lasting durability.

MAXIMIZED COST SAVINGS

- ① Each **e-smart** luminaire replaces up to three halogen downlights, saving 80%+ of energy and air conditioning costs.
- ② Quicker installation, easier handling and smaller volume of fixtures reduce the installation cost.
- ③ One 52 W **e-smart** downlight replaces up to 270 Watts from three 90PAR38 halogen potlights, and needs relamping only once in every two to three years.

When calculated with the required light levels and usage hours by today's energy costs, and the downsizing of air conditioning needed, **e-smart** provides an exceptional value to the end user: **It pays for itself.**

PRODUCT CODE	REFLECTOR	LAMP	BASE	BALLAST
3063.2PLC13.120	CLEAR	2 x 13W PLC	G24q-1 / 4P	Electronic*
3063.2PLC18.120	CLEAR	2 x 18W PLC	G24q-2 / 4P	Electronic*
3063.2PLC26.120	CLEAR	2 x 26WPLC	G24q-3 / 4P	Electronic*
3060.PLC13.120	CLEAR	13W PLC	G24q-1 / 4P	Electronic*
3060.PLC18.120	CLEAR	18W PLC	G24q-2 / 4P	Electronic*
3060.PLC26.120	CLEAR	26W PLC	G24q-3 / 4P	Electronic*
3060.PLT18.120	CLEAR	18W PLT	GX24q-2 / 4P	Electronic*
3060.PLT26.120	CLEAR	26W PLT	GX24q-3 / 4P	Electronic*
3060.PLT32.120	CLEAR	32W PLT	GX24q-3 / 4P	Electronic*
3060.PLT42.120	CLEAR	42W PLT	GX24q-4 / 4P	Electronic*
3060.MED.120	CLEAR	PAR38 TWIST	MED.	INTEGRAL
3066.PLT26.120	CLEAR	26W PLT	GX24q-3 / 4P	Electronic*
3066.PLT32.120	CLEAR	32W PLT	GX24q-3 / 4P	Electronic*
3066.PLT42.120	CLEAR	42W PLT	GX24q-4 / 4P	Electronic*
3066.MED.120	CLEAR	max. 34W	MED.	INTEGRAL

*Available in 120V, 277V, 347V and 240V/50Hz for International Markets
*Specify with proper suffix (e. g. -347V)



SIMPLIFIED WARRANTY SERVICE: One call to 1-800-49-LAMPS will take care of any warranty issues. Specifications are subject to change without notice. Manufactured in Canada by Valuelight, 612 Gordon Baker Rd. Toronto M2H 3B4